

CHKD	NAME	SIGNATURE	DATE
DRAWN	COLIN ALEXANDER		27/10/2021

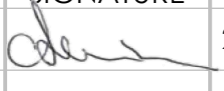

THIS DRAWING IS FOR REFERENCE ONLY.
USE VALVE MASTER DRAWINGS FOR MANUFACTURING DETAILS

DWG NO.
CODE 1 - CODE 36

A	INTRODUCED AS DOCUMENT QF37	21/10/2021
REV.	DESCRIPTION	DATE

					
CODE 37 - SS / RUBBER	CODE 40 - 316 SS	CODE 41 - 316 SS	CODE 43 - 316 SS / RUBBER	CODE 44 - 316 SS	CODE 45 - SS / RUBBER
					
CODE 46 - 316 SS	CODE 47 - 316 SS	CODE 48 - RUBBER	CODE 50 - RUBBER	CODE 51 - RUBBER	CODE 52 - 316 SS
					
CODE 53 - SS	CODE 54 - 316 SS	CODE 55 - 316 SS	CODE 56 - 316 SS	CODE 58 - 316 SS	CODE 59 - 316 SS
					
CODE 60 - 316 SS	CODE 61 - 316 SS	CODE 62 - BRASS	CODE 63 - 316 SS / BRASS	CODE 64 - SS	CODE 65 - 316 SS / RUBBER
					
CODE 67 - SS / RUBBER	CODE 68 - RUBBER	CODE 69 - SS	CODE 70 - RUBBER		

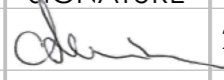
CHKD DRAWN	NAME	SIGNATURE	DATE
	COLIN ALEXANDER		27/10/2021



THIS DRAWING IS FOR REFERENCE ONLY.
USE VALVE MASTER DRAWINGS FOR MANUFACTURING DETAILS

DWG NO.
CODE 37 - CODE 70

A	INTRODUCED AS DOCUMENT QF37	21/10/2021
REV.	DESCRIPTION	DATE

					
CODE 71 - SS / RUBBER	CODE 72 - RUBBER	CODE 73 - SS	CODE 74 - 316 SS	CODE 75 - SS	CODE 76 - RUBBER
					
CODE 77 - SS	CODE 79 - RUBBER	CODE 80 - SS / RUBBER	CODE 81 - STAINLESS STEEL	CODE 82 - 304 SS / RUBBER	CODE 83 - 316 SS / RUBBER
					
CODE 84 - 316 SS	CODE 85 - 316 SS	CODE 86 - 316 SS	CODE 87 - 316 SS	CODE 88 - SS	CODE 89 - SS
					
CODE 90 - SS	CODE 91 - SS	CODE 92 - SS	CODE 93 - 316 SS	CODE 94 - 316 SS	CODE 95 - 316 SS
					
CODE 96 - 316 SS	CODE 97 - 316 SS	CODE 98 - 316 SS	CODE 99 316 SS / RUBBER / PTFE		

CHKD. DRAWN	NAME	SIGNATURE	DATE		THIS DRAWING IS FOR REFERENCE ONLY. USE VALVE MASTER DRAWINGS FOR MANUFACTURING DETAILS	DWG NO.	A	INTRODUCED AS DOCUMENT QF37	21/10/2021
	COLIN ALEXANDER		27/10/2021			CODE 71 - CODE 99	REV.	DESCRIPTION	DATE

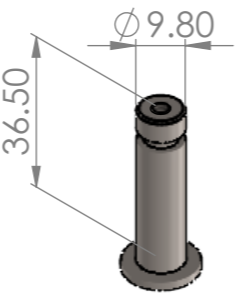
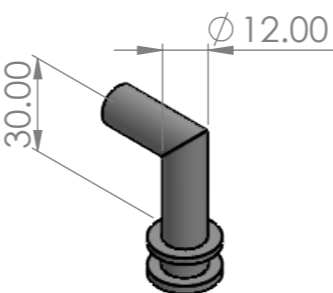
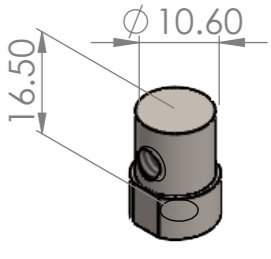
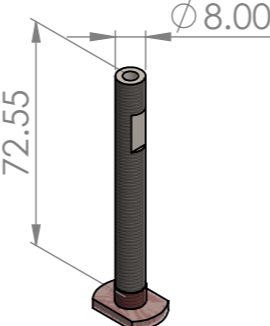
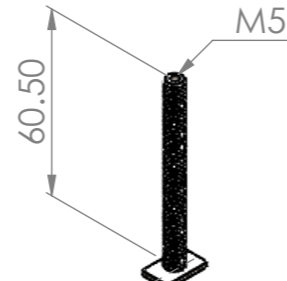
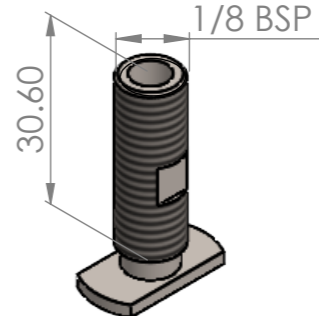
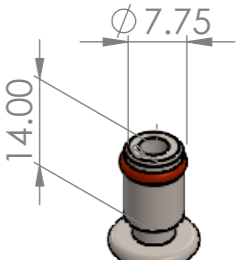
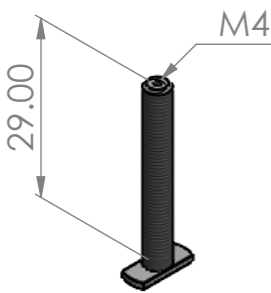
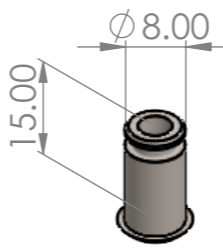
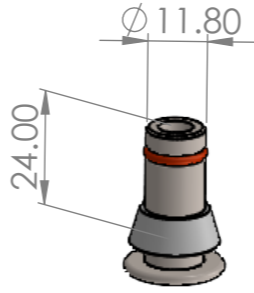
					
CODE 100 - 316 SS / RUBBER	CODE 101 316 SS / RUBBER / PTFE	CODE 102 - 316 SS	CODE 103 - RUBBER	CODE 104 - 304 SS	CODE 105 - 316 SS
					
CODE 106 - 316 SS	CODE 107 - 316 SS	CODE 108 - 316 SS	CODE 110 - 316 SS	CODE 111 - 316 SS	CODE 112 - SS / RUBBER
					
CODE 113 - RUBBER	CODE 114 - 316 SS	CODE 115 - 316 SS	CODE 116 - 316 SS	CODE 117 - 316 SS	CODE 118 - 316 SS
					
CODE 119 - 304 SS	CODE 120 - 316 SS	CODE 121 - RUBBER	CODE 122 - STAINLESS STEEL	CODE 123 - 316 SS / RUBBER	CODE 124 - 316 SS / RUBBER
					
CODE 125 - RUBBER	CODE 126 - 316 SS / RUBBER	CODE 127 - 316 SS / RUBBER	CODE 128 - 316 SS / RUBBER		

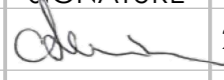
CHKD	NAME	SIGNATURE	DATE
DRAWN	COLIN ALEXANDER		27/10/2021



THIS DRAWING IS FOR REFERENCE ONLY.
USE VALVE MASTER DRAWINGS FOR MANUFACTURING DETAILS

DWG NO. **CODE 100 - CODE 128**

A	INTRODUCED AS DOCUMENT QF37	21/10/2021
REV.	DESCRIPTION	DATE

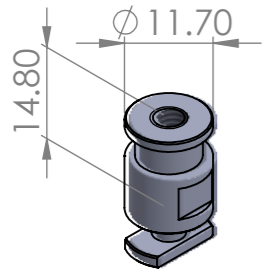

CODE 129 - 304 SS

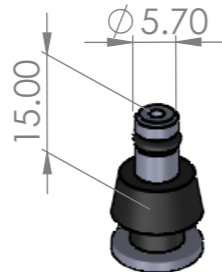

CODE 130 - 316 SS / RUBBER

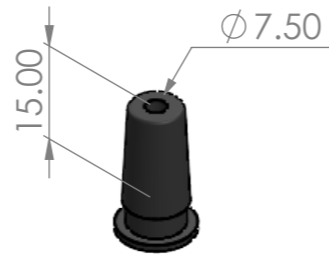

CODE 131 - RUBBER

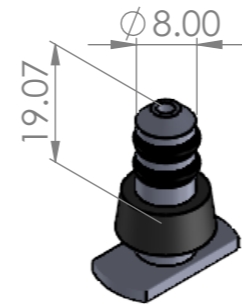

CODE 132 - 316 SS / RUBBER

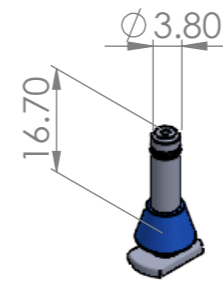

CODE 133 - 316 SS / RUBBER

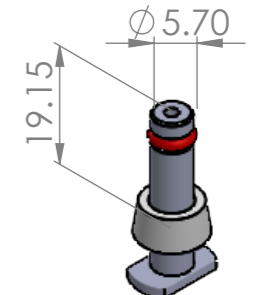

CODE 134 - 316 SS / RUBBER

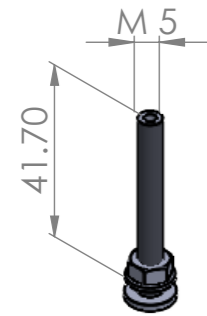

CODE 135 - 316 SS

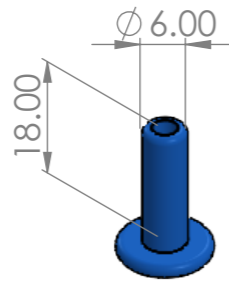

CODE 136 - RUBBER

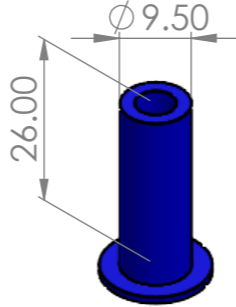

CODE 137 - RUBBER

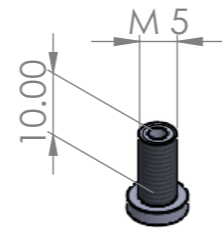

CODE 138 - 316 SS

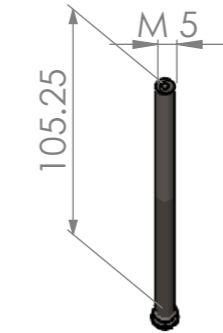

CODE 139 - STAINLESS STEEL

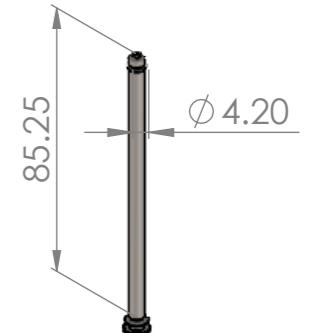

CODE 140 - STAINLESS STEEL

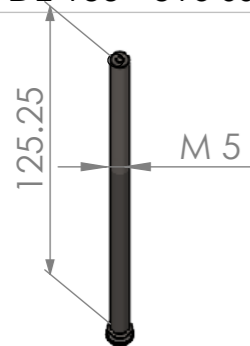

CODE 141 - STAINLESS STEEL

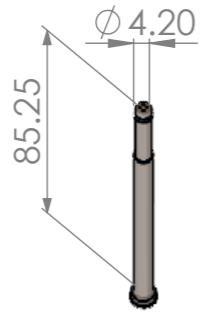

CODE 142 - STAINLESS STEEL

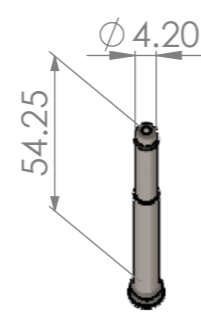

CODE 143 - STAINLESS STEEL

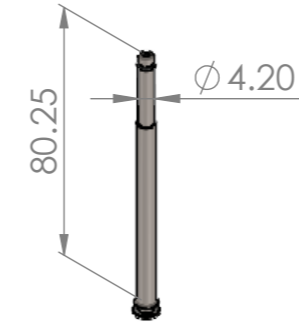

CODE 144 - STAINLESS STEEL

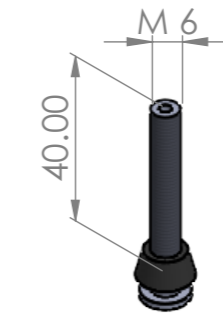

CODE 145 - 316 SS / RUBBER

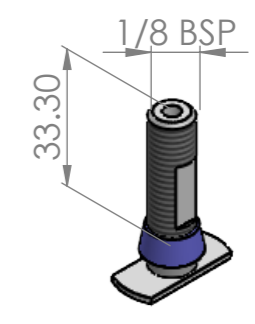

CODE 146 - 316 SS / RUBBER

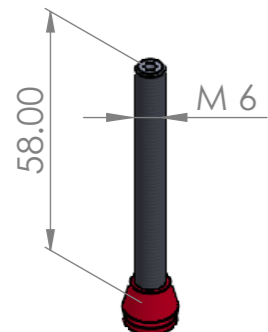

CODE 147 - 316 SS / RUBBER

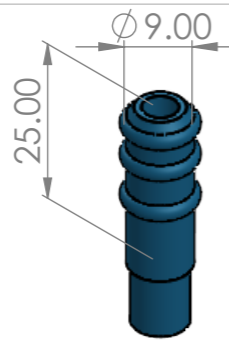

CODE 148 - RUBBER

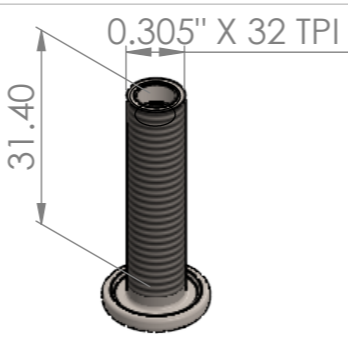

CODE 149 - STEEL

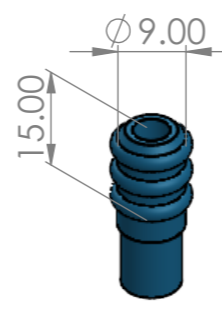

CODE 150 - RUBBER

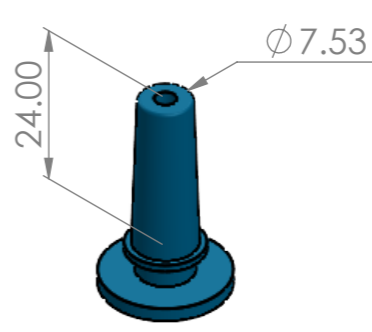

CODE 151 - RUBBER

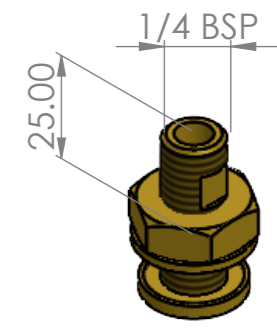

CODE 152 - BRASS

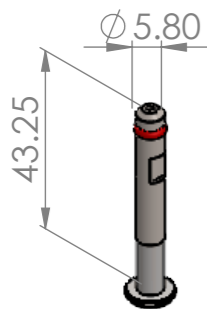

CODE 153 - 316 SS

CODE

CODE

CODE

CHKD	NAME	SIGNATURE	DATE
	COLIN ALEXANDER		27/10/2021



THIS DRAWING IS FOR REFERENCE ONLY.
USE VALVE MASTER DRAWINGS FOR MANUFACTURING DETAILS

DWG NO.
CODE 129 - CODE

A	INTRODUCED AS DOCUMENT QF37	21/10/2021
REV.	DESCRIPTION	DATE